

DOMUS NOVA



Villa Las Brisas - San Carlos

€9,700,000



A new six-bedroom, sea-view villa close to bohemian San Carlos with a new lease of life by renowned island architects Blakstad.

Renowned island architects Blakstad has been tasked with conserving the traditional character of this sea view villa, while bringing it into the 21st century.

True to the brief, clean lines, white plaster and floor-to-ceiling glazing contrast with stone arches and walls to add a rustic twist. Inside, an open-plan layout unites the refreshed interiors, spread over three levels.

A double height ceiling and window bathes the main living area in natural light. Positioned on the first floor to take advantage of the wide-reaching views, the sociable kitchen, living and dining space is configured for entertaining. A large island clad in wood, ceiling beams and an open fireplace soften the contemporary finish. Outside, there's an al fresco kitchen and seating area, with steps leading down to a pool surrounded by citrus trees.

Multiple terraces circle the villa, dotted with chill-out corners. All bedrooms – arranged between the basement and top floors – come with either terrace or garden access. In the master suite, soothing neutral tones bring an understated luxury and accentuate the generous space, which includes a dressing area and sleek bathroom.

There's a unique opportunity for a new owner to put their stamp on the property.

































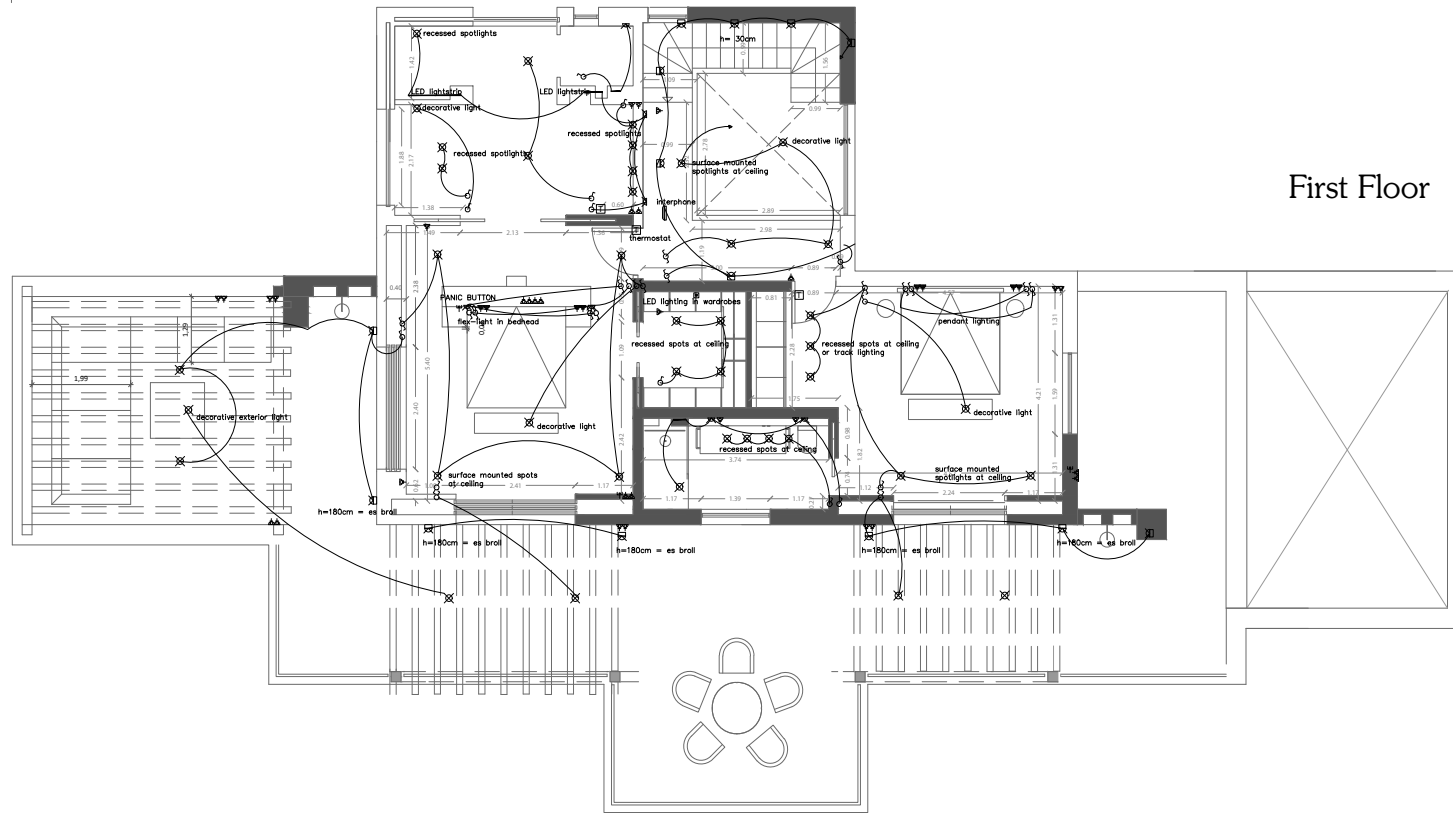
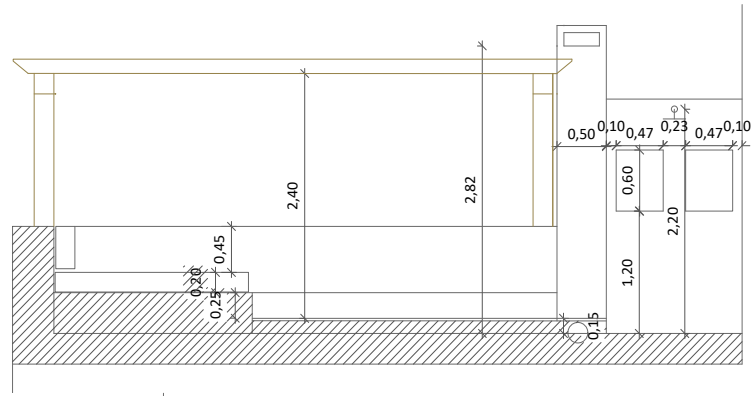

First Floor

Property Details

- 6 Bedrooms, 5 Bathrooms
- Blakstad Designed
- Sea and countryside views
- Swimming pool
- Multiple terraces
- Fenced plot with parking
- Air conditioning and underfloor heating through
- Alarm system
- Opportunity to put your own stamp on the property

Build size: 560 sq m
 Plot size: 15,000 sq m

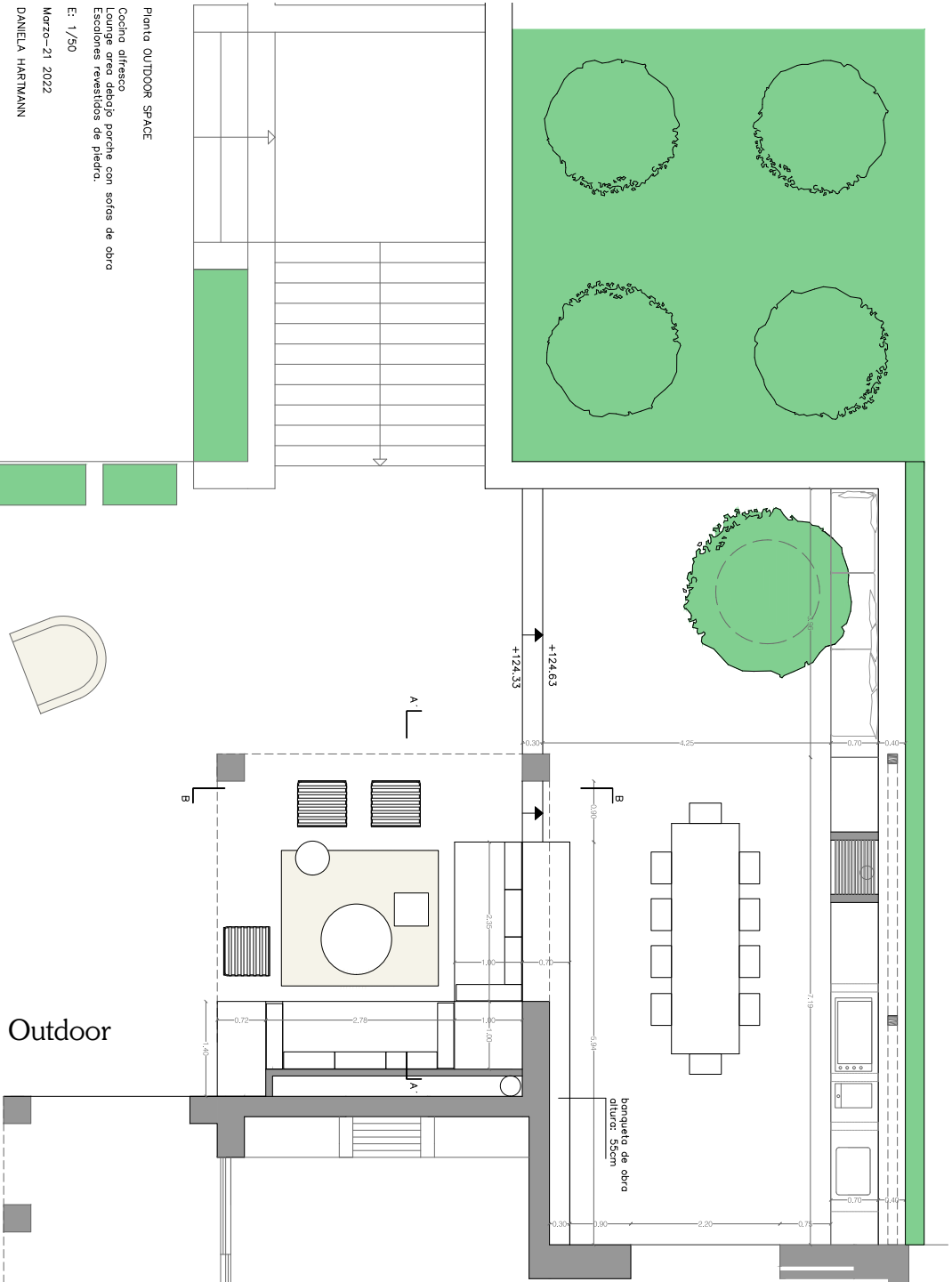

Planta OUTDOOR SPACE

Cocina al fresco
 Lounge area debajo porche con solas de obra
 Escalones revestidos de piedra.

E: 1/50

Marzo-21 2022

DANIELA HARTMANN

Outdoor



Location

Close to the village of San Carlos, a long-time haven for free-spirits, Villa Las Brisas offers a peaceful base from which to explore the island's calmer north-eastern corner. Catch up on the local news over a drink at Anita's Bar or peruse the hippy market at nearby Las Dalias. Take your pick of peaceful beaches – from the golden, cliff-backed sands at Aguas Blancas to the rolling waves at Cala Nova, one of Ibiza's top surfing spots.

Ibiza airport (35 mins)
Ibiza Town (25 mins)
Aguas Blancas (10 mins)
Cala Nova (10 mins)

Specialising in London
and Ibiza's design-led homes

Let's talk

+34 871 515 302

ibizasales@domusnova.com

domusnova.com/ibiza

The property particulars are a guide not statements. Descriptions, photographs, and plans are for guidance and should be checked a prospective purchaser or tenant.

The Property is offered "subject to contract". No warranties, representations, or Tenancy is given by Domus Nova. Expenses incurred by a prospective tenant or buyer will not be reimbursed if the Landlord or the Seller withdraws prior to the Tenancy Agreement being signed, dated and exchanged and cleared funds received. Further details of the Disclaimer together with trading names and our Privacy Policy is shown on our website. The IVA position relating to the property may change without notice.

View our privacy policy on how your data is processed and used. To find out how we process Personal Data, please refer to our Privacy Statement and other notices on our website which can be found [here](#).